

BASIC CONCEPTS

This module is an introduction to the low-level operation of microprocessor-based computer systems. We will cover the operation of the Central Processing Unit, Memory, and I/O devices. This module is primarily a programming module, however it will also focus on the understanding and operation of the hardware and advanced architectural concepts.

The programming part of the module is in Assembly Language using the **Intel® 80X86** as the target processor, and **MS-DOS** as the target operating environment. Many of the programming exercises in the labs are geared around programming and controlling input/output devices. The programming tools used will be **Microsoft® MASM 6.15**, and if time permits **GNU NASM**. The Microsoft tool use **PWB** (Programmer's Workbench) as the IDE with **CodeView** as the debugger. You can always refer to my website at <http://pages.intnet.mu/rhh> or my intranet site at <http://inraweb/~rh> on which module materials will be posted. These will include lecture notes, assignments, and other resources.

Evolution of computers and the development of the microprocessor

- Originally, computer was a job description. It meant someone whose job was to calculate things.
- With the invention of programmable machines, the word changed to mean the machine that did the calculation.
- Early computers required some rewiring to change operations. Eventually, the stored program concept was invented.

Two contrasting architectural types

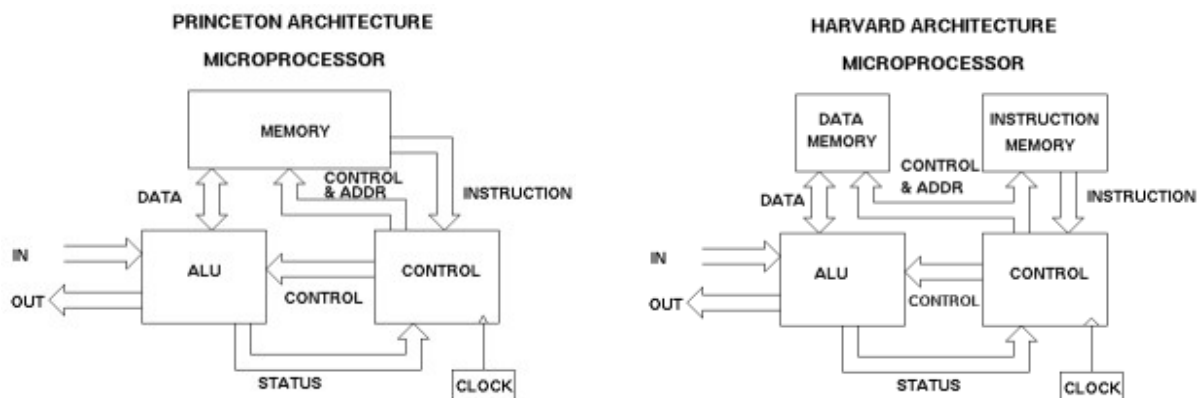

Invention of Microprocessor

- Contains all of the functions of the CPU on a single integrated circuit.
 - 8088: 16 bits code and data, real mode operation
 - 80286: 16 bits code and data, real and protected mode operation
 - 80386: 32 bits code and data, real mode, virtual 86 mode and protected mode
 - 80486: integrates **math co-processor** functions with on same chip
 - Pentium and beyond: **Superscalar** architecture

CPU – Central Processing Unit

The CPU controls the operation of the computer: executes instructions, generates timing to control operation of rest of system. Various kinds of co-processors exist in some systems, which extend the instruction set of the main CPU.

Memory

Memory consists of array of memory locations. It can be organized as bits, bytes, words or double words. Types of Memory: RAM: SRAM, DDRAM, RDRAM and ROM: EPROM, EEPROM, Flash Memory

Input/Output: Memory mapped vs. I/O mapped

Some processors have a separate address space for I/O devices (e.g. 8080, Z80, 80x86), other processors have only a memory address space and expect that I/O devices will be in the same address space as memory. (e.g. 68HC11, 68000)

Serial I/O

Data is presented in a bit serial format. Varies with word size, and bit order as well as type of clocking e.g. Asynchronous, RS-232, Synchronous, USB, PS/2 keyboard and mouse

Parallel I/O

Data is presented with all data bits at the same time on multiple lines e.g. Printer port, SCSI interface

System Bus - Interfacing between different parts of the computer system. *Address Bus*: Carries address information from the CPU. *Data Bus*: Carries instructions & data between the CPU and memory and I/O devices. *Control Bus*: Carries control and timing signals between the CPU and the rest of the system.

Microprocessor Operation

Machine Cycles: *Instruction Fetch, Information Decode, Information Execute, Information Store*

Bus Cycles: *Memory Read, Memory Write, I/O Read, I/O Write, Interrupt Acknowledged*

Addressing Modes

The microprocessor instructions operate on data. The addressing mode for the instruction informs the processor how to find the data (operands) for the instruction to operate on.

Register: The operand is contained in one of the processor registers: e.g. *mov ax,bx*

Immediate: The operand is included as part of the instruction. e.g.: *mov ax, 1*

Direct: The address of the data is included in the instruction. e.g.: *mov ax,var1*

Register Indirect: The address of the data is specified by one of the following registers: BX, SI, DI. e.g.: *mov ax,[bx]*

Indexed: The address of the data is contained in an index register, plus an optional offset. e.g.: *mov ax,[si+5]*

Based: The address of the data is contained in a base register, plus an optional offset. e.g.: *mov ax,[bp+5]*

Based Indexed: The address of the data is contained in the sum of a base register plus an index register, plus an optional offset. e.g.: *mov ax,[bx][di]+5*

Interrupts

There are **three** basic types of interrupt:

Hardware Interrupts: Generate by external hardware associated with some I/O device. NMI – Non-maskable interrupt; is generated by signal on the NMI pin and can not be disabled in software.

Regular interrupt: Generated by signal on the INT pin on the processor. Vector is supplied by external interrupt controller hardware in response to interrupt acknowledge cycle by processor.

Software Interrupts: These are generated by the execution of an instruction in the program. Exceptions generally indicate errors detected by the processor during the execution of the program.

Improving Computer Performance: How can we make computers faster?

The Fetch-Decode-Execute-Store Cycle and Pipelining

The fetch-execute cycle represents the fundamental process in the operation of the CPU, attention has been focused on ways of making it more efficient. One possibility is to improve the speed at which instructions and data may be retrieved from memory, since the CPU can process information at a faster rate than it can retrieve it from memory.

The use of a **cache** memory system, which is discussed later, can improve matters in this respect. Another way of improving the efficiency of the fetch-execute cycle is to use a system known as **pipelining**. The basic idea here is to break the fetch-execute cycle into a number of separate stages, so that when one stage is being carried out for a particular instruction, the CPU can carry out another stage for a second instruction, and so on. This idea originates from the assembly line concept used in the manufacturing industry.

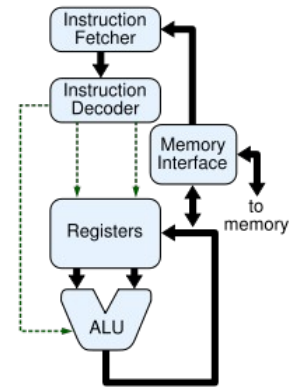

Consider a simplified car manufacturer’s garage where only one mechanic works on a particular stage at a time. While the car is in one stage, the other 4 mechanics are idle and are waiting for their stage to come so they can work on the car as shown in Fig. 1, so one car is completed after every 5 hours.

In an assembly line, for example, if a car goes through 5 stages before being completed, then we can have up to five cars being operated on at the same time on the assembly line. If, for the sake of simplicity, we assume that each stage takes one hour to complete, then it will take 5 hours to complete the first car since it will be processed for 1 hour at every stage on the assembly line.



Fig. 1: No Assembly Line Production

However, when the first car has moved to the second stage of the assembly line, we can start work on a second car at the first stage of the assembly line. When the first car moves on to the third stage, the second car can move on to the second stage and a third car can be started on the first stage of the assembly line. This process continues, so that when the first car reaches the 5th and final stage, there are 4 other cars in the first four stages of production as in Fig. 2. This means that when the first car is finished after 5 hours, another car will be completed **every hour** thereafter.

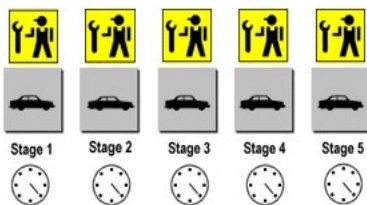

Fig. 2: Assembly Line Production

The great advantage of assembly line production is the increase in throughput that is achieved. After the first car is completed we continue

production with a throughput of one car per hour. If we did not use a pipelined assembly line and worked on one car at a time, each car would take 5 hours to produce; the throughput would be 1 car per 5 hours. For example, the time taken to complete 20 cars on the assembly line is 24 hours, while without using the assembly line, the time taken would be 100 hours. It should be noted that on the assembly line, each car still requires 5 hours of processing, i.e. it still takes 5 hours of work to produce a car, the point is that because we are doing the work in stages, we can work on 5 cars at the same time, i.e. in parallel.

Flowthrough Time

The time taken for all stages of the assembly line to become active is called the **flowthrough** time, i.e. the time for the first car to reach the last stage. Once all the assembly line stages are busy, we achieve **maximum throughput**.

We have simplified the analysis of the assembly line and in particular the assumption that all stages take the same amount of time is not likely to be true. The stage that takes the longest time to complete creates a bottleneck in an assembly line. For example, if we assume that stage 2 in our car assembly line takes 3 hours then the throughput decreases to 1 car per 3 hours. This is because stage 3 must wait for 3 hours before it can begin and this delay is passed on to the remaining stages, slowing the time to complete each car to 3 hours.

Clock period

We can express this by saying the **clock period** of the assembly line (time between completed cars) is 3 hours. The clock period, denoted by T_p , of an assembly line is given by the formula:

$$T_p = \max(t_1, t_2, t_3, \dots, t_n)$$

where t_i is the time taken for the i^{th} stage and there are n stages in the assembly line. This means that the clock period is determined by the time taken by the stage that requires the most processing time.

In a non-pipelined system, the total time T , taken to complete a car, is the sum of the time for the individual stages, i.e. $T = t_1 + t_2 + t_3 + \dots + t_n$

If all stages take 1 hour to complete, then $T = 5$ hours, it takes 5 hours to complete every car.

If stage 2 takes 3 hours and the other stages take 1 hour to complete then T rises to 7 hours and it will take 7 hours to complete every car.

Throughput

We can define the **throughput** of an assembly line to be $1/T_p$. Using this definition, the throughput for our assembly line where all stages take 1 hour is $1/1$, i.e. 1 car/hour. If we assume stage 2 takes 3 hours to complete, the throughput falls to $1/3$ or .333 cars/hour. For non-assembly line production the respective throughputs are $1/5$ or .2 cars/hour and $1/7$ or .143 cars/hour.

Pipelining

The same principle as that of the assembly line can be applied to the fetch-execute cycle of a processor where we refer to it as **pipelining**:

1. **Fetch an instruction from memory**
2. **Decode the instruction using CU**
3. **Execute the instruction using ALU**
4. **Store result in either memory or write-back to register**

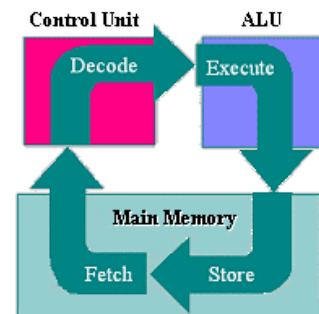

Assuming each stage takes one clock cycle, then in a non-pipelined system, we use 5 cycles for the first instruction, followed by 5 cycles for the second instruction and so on, as illustrated in Fig. 3:



Fig. 3: Non-pipelined CPU. It takes 15 cycles to complete 3 instructions

The throughput for such a system would be 1 instruction per 5 cycles. If we adopt the assembly line principle, then we can improve the throughput dramatically. Fig. 4 illustrates the fetch-execute cycle employing pipelining.



Fig. 4: CPU with pipelining

Using **pipelining**, we overlap the processing of instructions, so that while the first instruction is in the decode stage; the second instruction is being fetched. While the first instruction is in the execute stage, the second instruction is in the decode stage and the third instruction is being fetched.

After the first 5 cycles, the first instruction is completed and thereafter an instruction is completed on **every cycle** as opposed to a throughput of 5 cycles per instruction in a non-pipelined system. Again, as in the assembly line example, each instruction still takes the same number of cycles to complete, the gain comes from the fact that the CPU can operate on instructions in the different stages in **parallel**. The clock period and throughput of a pipeline are as defined for the assembly line above:

Clock period $T_p = \max(t_1, t_2, t_3, \dots, t_n)$ for n stage pipeline

Throughput = $1/T_p$

The above description is quite simplified, ignoring the fact for example that all stages may not be completed in a single cycle. It also omits stages that arise in practice such as an **operand fetch** stage, which is required to fetch an operand from memory, or a **write back** stage to store the result of an ALU operation in a register or in memory. In practice, pipelined systems range from having 3 to 10 stages, for example, Intel’s Pentium microprocessor uses a 5-stage pipeline for integer instructions. There are difficulties in pipelining that would not arise on a factory assembly line, due to the nature of computer programs. Consider the following 3 instructions in a pipeline:

```

    jg label    (if previous comparison is positive then jump to label)
    mov y, 0
    mov x, 3
label:  ....
    
```

When the *lg* instruction is being executed, the following two instructions will be in earlier stages, one being fetched and the other being decoded. However, if the *lg* instruction evaluates the condition to be true, it means that the two move instructions will not be executed and new instructions have to be loaded, starting at the instruction indicated by *label*. This means that we have to flush the pipeline and reload it with new instructions. The time taken to reload the pipeline is called the **branch penalty** and may take several clock cycles. Branch instructions occur very frequently in programs and so it is important to process them as efficiently as possible.

A technique known as **branch prediction** can be used to alleviate the problem of conditional branch instructions, whereby the system "guesses" the outcome of a conditional branch evaluation before the instruction is evaluated and loads the pipeline appropriately. Depending on how successfully the guess is made, the need for flushing the pipeline can be reduced. When the branch has been evaluated, the processor can take appropriate action if a wrong guess was made. In the event of an incorrect guess, the pipeline will have to be flushed and new instructions loaded.

Branch prediction is used on a number of microprocessors such as the Pentium and PowerPC. Successful guesses ranging from 80% to 85% of the time are cited for the Pentium microprocessor. Another technique is to use **delayed branching**. In this case, the instruction following the conditional jump instruction is always executed.

For example, if the conditional jump instruction is implementing a loop by jumping backwards, it may be possible to place one of the loop body instructions after the conditional jump instruction. If a useful instruction cannot be placed here, then a nop instruction can be used.

Increasing Execution Speed: More Hardware

Consider the following two instructions:

add i, 10 (*this is equivalent to $i=i+10$*)

add x, y (*this is equivalent to $x=x+y$*)

In a simple processor these instructions would be executed in sequence by transferring the operands to the ALU and carrying out the addition operations.

One way of speeding things up is to have two ALUs so that the instructions can be carried out at the same time, i.e. the two ALUs can carry out the instructions in parallel. This idea is now widely employed by the current generation of microprocessors such as the Pentium, PowerPC and Alpha.

The term **superscalar** is used to describe architecture with two or more functional units which can carry out two or more instructions in the same clock cycle.

These may include integer units (IUs), floating-point units (FPUs) and branch processing units (BPUs, devoted to handling branch instructions).

The micro-architecture of a hypothetical superscalar processor is illustrated in Fig. 5. The term micro-architecture is used to refer to the internal architecture of a processor.

The processor shown in Fig. 5 has three execution units and could execute 3 instructions concurrently, in theory. The register file is the collective name given to the CPU's registers. A processor with an on-chip FPU would have a separate set of floating-point registers (FPRs) in addition to the usual general purpose registers (GPRs).

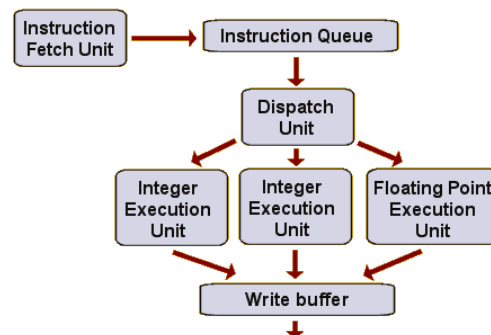

Fig. 5: Architecture of a superscalar processor

The cache memory is used to speed up the processor's access to instructions and data (see later). The extra functional units allow the CPU carry out more operations per clock cycle. Fig. 6 illustrates the fetch-execute cycle for a superscalar architecture, with two functional units operating in parallel.

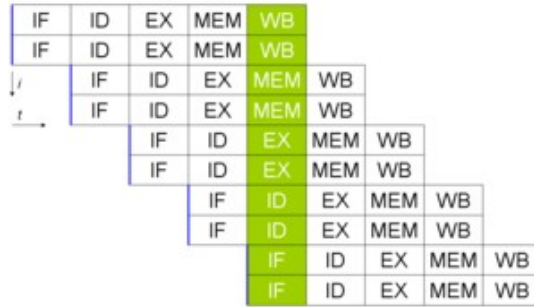

Fig. 6: Superscalar Architecture fetch-execute cycle

As can be seen from Fig. 6, two instructions are in each stage of the pipeline at the same time, doubling the throughput of the pipeline, in theory. If we consider cycle 3 we can see that the processor is handling six stages of six instructions at the same time. In practice, this can give rise to a number of problems, since there are situations that arise, which mean that instructions cannot be executed in parallel. One problem that arises is that of **inter-instruction dependencies**.

Consider the following three sequential instructions:

sub r1, x (this is equivalent to $r1=r1-x$)
add r1, 2 (this is equivalent to $r1=r1+2$)
sub r0, r3 (this is equivalent to $r0=r0-r3$)

The first two instructions (*add* and *sub*) cannot be carried out in parallel as they both modify the same operand, *r1*, giving rise to a data dependency. A data dependency arises between two instructions if the destination operand of one instruction is accessed by the other instruction. In this particular example, a solution is possible called **instruction reordering (scheduling)** because by reordering the instructions in the sequence:

sub r1, x
sub r0, r3
add r1, 2

The two *sub* instructions can now be executed in parallel, since their operands do not conflict with each other. This is a software solution and can be implemented by a compiler, when translating a program to machine code. The compiler software must be aware of the processor's superscalar architecture for this solution to be implemented.

This is why processor aware compilers and native compilers are very important, if programs are to take advantage of the advanced features of a processor. For example, a compiler that only generates code for an Intel 80386 can also be used on a PC with Intel's Pentium processor. However, the code produced will not perform nearly as well, as code produced by a native Pentium compiler. The number of functional units for a superscalar architecture typically varies from 3 to 5 while the number of instructions that a machine may issue in a cycle typically varies from 1 to 3. An important implication of the superscalar fetch-execute pipeline as illustrated in Fig. 6, is that since two instructions are fetched at the same time, the CPU bus must be wide enough to transfer the two instructions to the control unit. It is important to point out, that pipelining and superscalar designs require rapid access to data and instructions if they are to be successful in improving performance. The provision of on-chip cache memory, as described later, facilitates such rapid access.

Parallel Computers

Another very important technique for increasing a computer's performance is the use of more than one processor in a computer system, e.g. in a multi-processor or parallel computer. Such machines may have from 2 to many 1000s of interconnected processors. Each processor may have its own private memory or they may share common memory. One of the difficulties with such machines is the development of software to take advantage of their parallel nature. It is important to note that such machines will only yield significant performance gains if the problems they are being used to handle can be expressed in a parallel form. Manipulation of matrices is one such problem. E.g., given two 10,000 element matrices which have to be summed to produce a third matrix, and a parallel machine with 10,000 processors, one processor can be dedicated to the addition of each pair of elements. Thus, crudely, the computation can be carried out in the time taken for the addition of one pair of elements, since the 10,000 processors can carry out the operation in parallel. The same operation on a conventional processor would require the time taken for all 10,000 additions. The performance gain is striking as long as the problem is precisely suited to a parallel machine. A major design issue in the construction of parallel computers is how the processors communicate with each other and memory.

Increasing Execution Speed: Faster Clock

The clock speed of a computer determines the rate at which the CPU operates. It is measured in megahertz (MHz) or millions of cycles per second. Early microcomputers had a clock in the low MHz range, e.g. 1 to 4 MHz. With advancing chip technology, higher and higher clock speeds have been obtained. Standard personal computers currently run at typical speeds in the 3000 MHz to 4000 MHz.

To gain some insight into clock speed, consider a 100 MHz clock rate. At 100 MHz, each clock cycle takes one hundredth of a millionth of a second, i.e. 0.01 microseconds or 10 nanoseconds. Light travels at about 1 foot per nanosecond, so one clock cycle of a 100 MHz clock takes the same amount of time as the time light takes to travel 10 feet!

The Von Neumann bottleneck

It should be noted that increasing the clock speed does not guarantee significant performance gain. This is because the clock speed is effectively determined by the rate at which it can fetch instructions & data from memory. Thus if a processor spends 90% of its time waiting on memory, the performance gained by doubling the processor speed (without improving the memory access time) is only 5%.

E.g. Assume a task takes 100 units of time, and 90 units are spent waiting on memory access with 10 units spent on CPU processing. By doubling the CPU speed, CPU processing time is reduced to 5 units and so the overall time is reduced to 95 time units, i.e. a 5% improvement. It is obviously important then to reduce the time the CPU has to wait for memory accesses. This is the **Von Neumann bottleneck** - caused by a mismatch in speed between the CPU and memory. The CPU can process data at a low nanosecond rate while RAM can only deliver it at a high nanosecond rate. For example, if RAM delivers data to the CPU at a rate of 100ns per data item (10 million items per second!) and the CPU can consume data at say 5ns per item, then the CPU will still spend 95% of its time waiting on memory.

I/O Delays

The processor will also usually have to wait for I/O operations to complete and indeed it is usually the case that I/O speeds determine the speed of program execution. Recall that it is of the order of 100,000 times slower to retrieve data from disk than it is to retrieve it from memory. This means that for programs that carry out I/O, the processor is idle most of the time, waiting for the I/O operations to complete. This in turn, means that using a more powerful processor to execute such programs, results in very little gain in overall execution speed.

Improving Memory Access Time: Cache memory

One way of improving memory access time involves the use of a cache memory system. The processor operates at its maximum speed if the data to be processed is in its registers. Unfortunately, register storage capacity is very limited and so memory is used to store programs and data. One, very effective way of overcoming the slow access time of main memory, is to design a faster intermediate memory system that lies between the CPU and main memory. Such memory is called **cache memory** (or simply cache) and it may be visualised as in Fig. 8.

Early systems had small cache memory systems measured in kilobytes, compared to today's megabyte cache memory systems. Cache memory is high speed memory (e.g. SRAM) which can be accessed much more quickly than normal memory (usually dynamic RAM (DRAM)). It has a smaller capacity than main memory and it holds recently accessed data from main memory. The reason why cache memory works so well in improving performance is due to what is known as the **principle of locality of reference**. This roughly means that having accessed a particular location in memory, it is highly likely that you will access neighbouring memory locations subsequently.

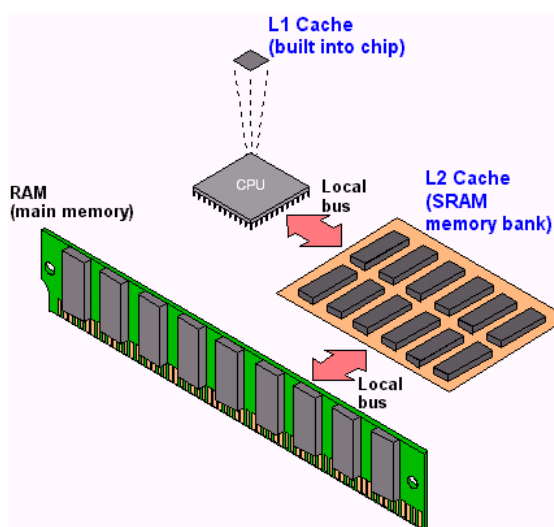

Fig. 8: Cache Memory

This is because:

- **programs tend to execute instructions sequentially and instructions are found in neighbouring memory locations**
- **programs often have loops whereby a group of neighbouring instructions are executed repeatedly**
- **arrays of data elements get accessed sequentially**

As a result, when an instruction or data element is fetched from memory, if you also fetch its neighbouring instructions or data elements and store them in cache memory, then it is very likely that the next item to be fetched will be in cache memory and can be obtained very quickly, relative to accessing it in main memory.

Cache memory operates so that when the CPU initiates a memory access (for data or an instruction), the cache memory is first checked to see if the information is already there. If it is there (called a **cache hit**), it can be transferred to the CPU very quickly. If the information is not in cache memory (a **cache miss**), then a normal memory access occurs, but, the information is passed to both the CPU and the cache memory. In addition, while the CPU is using the information, the cache memory system fetches nearby information from memory, independently of the CPU, so that if neighbouring information is required (a likely event), then it will already be in cache memory and can be accessed very quickly. If enough cache memory is available, the instructions making up a loop in a program could be stored in cache. This would mean that the loop could be executed an arbitrary number of times without causing any memory fetches for instructions, after the instructions have been initially fetched. This can yield great improvements in program execution speeds. In this way a cache hit rate of 90% and greater is possible, i.e. 90% or more of information requested by the CPU is found in cache memory, without the CPU having to access main memory. The speed of a memory system using cache memory is the weighted average of the cache speed and main memory speed.

*For example, assume a 100 ns delay for main memory and 20 ns delay for cache memory with a 90% hit rate, then the apparent speed of memory access is $(0.9 * 20) + (0.1 * 100) = 28\text{ns}$.*

This is a significant improvement in memory access performance, since the access time is now on average 28ns as opposed to 100ns if cache memory was not used.

Cache memory is now also included on the CPU chip (on-chip cache) of many microprocessors such as Intel's Pentium microprocessors, Digital's Alpha microprocessor and the IBM/Apple PowerPC microprocessor. Since the cache memory is on the CPU chip, the speed of cache memory access is improved over that of off-chip cache memory. The capacity of on-chip cache memory varies from 128 KB to around 2 MB at the moment while off-chip cache memory has disappeared. Computers may use separate memories to store instructions and data and such architecture is called a **Harvard Architecture** because this idea emerged from machines built at Harvard University. Instructions and data may be stored in the same cache memory which is referred to as a unified cache memory. Alternatively, separate caches for instructions and data may be maintained along the lines of the Harvard Architecture. The advantage of the Harvard Architecture is that instructions and data can be fetched simultaneously, i.e. in parallel, since they will be connected to the other CPU components by separate buses.

Measuring Computer Performance

How can we compare the performance of different computer systems? It is important to consider the performance of a computer system as a whole, including both the hardware and software and not just to consider the performance of the components of the system in isolation. It is very important to understand that measuring computer performance is a very difficult problem. There are a number of criteria that can be used for measuring the performance of a computer system and it is a non-trivial matter as to how to weigh up the relative importance of these criteria when comparing two computer systems. In addition, it is not easy to obtain totally objective information about different manufacturers' machines or to get the information in a form that makes it easy to use for comparison purposes.

Computer Performance Metrics

There are a number of ways of measuring the performance of a computer system or indeed that of the components that make up a computer system. One common measure is processor speed. The question of how to measure processor speed is not as simple as it appears. One simple measure is the number of instructions that can be executed per second, expressed in **millions of instructions per second** or **MIPS**. So, a given processor might have a processor speed of **5 MIPS**, i.e. it can execute **5 million instructions per second**. But, all instructions do not take the same amount of execution time. An instruction to clear a register might take 1 clock cycle. A multiplication instruction might take more than 10 clock cycles. The way to compute the MIPS rate more usefully is to calculate the average time the processor takes to execute its instructions, weighted by the frequency with which each instruction is used. However, the frequency of instruction usage depends on the software being used. So for example, word processing software would not require much use of a multiplication instruction whereas spreadsheet software would be more likely to use many multiplication instructions. When we compare the MIPS rate of two different machines, we must ensure that they are counting the same type of instructions. Another problem with the MIPS metric, is that the amount of work an individual instruction carries out, varies from processor to processor. For example, a single VAX *add* instruction is capable of adding two 32-bit memory variables and storing the result in a third memory variable, whereas a machine such as the 8086 requires three instructions (e.g. an *add* and two *mov* instructions) to accomplish the same task. Naively counting the number of add instructions that can be executed per second on these two machine will not give a true picture of either machines performance. We must also remember to take account of the processor word size when comparing instruction counts. A 32-bit processor is a more powerful machine than a 16-bit processor with the same MIPS rate, since it can operate on 32-bit operands as opposed to 16-bit operands. Similarly, a 64-bit processor will be more powerful than a 32-bit processor with the same MIPS rating.

Another metric that is similar to the **MIPS** rate is the **FLOPS** or **floating-point operations per second** rate which is expressed in megaflops (**MFLOPS**) and gigaFLOPS (**GFLOPS**). This metric is used particularly for machines targeted at the scientific/engineering community where a lot of applications software requires large amounts of floating-point arithmetic executed more quickly than others (e.g. addition versus division). Like the MIPS metric, the FLOPS metric needs to be approached with caution. The MIPS and MFLOPS metrics are concerned with processor speed. The processor is a crucial component of a computer system when it comes to performance measurement but it is not the only one and, in fact, it may not be the determining factor of the performance of a system. Other components are the memory and I/O devices whose performances are also crucial to the overall system performance. For example, a database application may require searching for information among millions of records stored on hard disk. The dominant performance metric for such an application is the speed of disk I/O operations. In such an application, the CPU spends most of its time waiting for disk I/O operations to complete. If we use a faster processor without increasing the speed of the disk I/O operations, then the overall improvement in performance will be negligible. I/O performance may be measured in terms of the number of megabytes that can be transferred per second (I/O bandwidth). This can be deceptive, as the maximum transfer rate quoted may not be achieved in practice. Take disk I/O, if the information required is stored on different tracks, then the seek time to move the head to the required tracks will slow I/O down considerably, whereas if the information is on the same track it can be transferred much more quickly. Another measure is the number I/O operations that can be completed per second, which can take account of the fact that the

information may not be conveniently available on disk. Memory performance is often measured in terms of its access time, i.e. the time taken to complete a memory write/read operation which is in the 10-100 ns range. The amount of memory present is also a very important factor in system performance. The larger the amount of memory present, the less likelihood for page faults to occur in a virtual memory system.

Overall system performance is determined by the performance of the processor, memory and I/O devices as well as the operating system and applications software performance. One measure of system performance to take account of the processor, memory and I/O performance is the number of **transactions per second (TPS)** that the system can cope with. A transaction might be defined as the amount of work required to retrieve a customer record from disk, update the record and write it back to disk, as modelled on a typical bank transaction. System performance can also be evaluated by writing benchmark programs and running the same benchmark program on a series of machines. A benchmark program is one written to measure some aspect of a computer's performance. For example, it might consist of a loop to carry out 1 million floating-point additions or a loop to carry out a million random read/write operations on a disk file. The time taken to execute the benchmark program gives a measure of the computer system's performance. By constructing a number of such programs for the different aspects of a systems performance, a suite of benchmarks may be developed that allow different computer systems to be compared. Benchmark programs are also used to test the performance of systems software such as compilers. The size of the executable file produced by the compiler and the efficiency of the machine code are two metrics that are used to compare compilers. Another system performance measure is the **SPECmark** which is obtained in a similar fashion to the use of benchmark programs, except instead of using contrived benchmark programs, a suite of ten real world application programs are used (these include a compiler application, a nuclear reactor simulation and a quantum chemistry application).

SPECmarks are used by companies such as Sun and Hewlett Packard to measure the performance of their workstations. One difficulty about using benchmarks and SPECmarks to evaluate system performance is that you are dependent on a compiler to translate the programs into efficient machine code for the computer under evaluation. However, compilers are not all equally efficient and particularly with the advent of new processor features such as multiple functional units capable of parallel operation, compiler writers have a complex task in designing good so-called optimising compilers. The code produced by a poor quality compiler can run significantly slower and use more memory than code produced by a good compiler. Other non-performance issues that arise when comparing computer systems are the actual cost of the system, and its reliability together with the availability of hardware and software support. Computer systems fail due to either hardware or software problems, or both. It is fundamentally important to take account of computing failures, from the moment of evaluating a new system right through to its day to day operation. There's no point in having the most sophisticated computer system in the world, if when it fails, you cannot get it operational again, in a short period of time. In summary, evaluating computer system performance is fraught with difficulties and the use of apparently simple metrics such as MIPS and MFLOPS can be quite misleading. The reality is that there is no easy alternative to that of running real world application programs (preferably the ones you wish to use) and choosing the system which best matches the performance criteria that you have laid down.