

BEE2102C - Controlled Assignment

It is advisable to email me a word-processed document of your answers without forgetting your index number.

Section A (45 marks)

Select the correct answer for the following 15 MCQs. (15 x 3 marks)

- Which one of the following does NOT represent Exclusive-NOR of a and b?
 A. $a'b' + ab$ B. $a \oplus b'$ C. $a' \oplus b$ D. $a' \oplus b'$
- What is the minimum number of gates required to implement the Boolean function $\mathbf{AB+C}$ if we have to use only 2-input NOR gates?
 A. 2 B. 3 C. 4 D. 5
- What is the minimal form of the Karnaugh map shown below? (x denotes don't care term)

- A. $b'd' + a'b'c'd'$
- B. $b'd' + b'c' + c'd'$
- C. $b'd' + b'c'$
- D. None of the above

	cd \ ab	00	01	11	10
00	1	x	x	1	
01	x			1	
11					
10	1			x	

- The simplified SOP form of the Boolean expression $(\mathbf{P + Q' + R'}) \cdot (\mathbf{P + Q' + R}) \cdot (\mathbf{P + Q + R'})$ is
 A. $P + Q' \cdot R'$ B. $P' \cdot Q + R'$ C. $P \cdot Q + R$ D. $P' \cdot Q + R$

- Which one of the following circuits is NOT equivalent to a 2-input XNOR (exclusive NOR) gate?

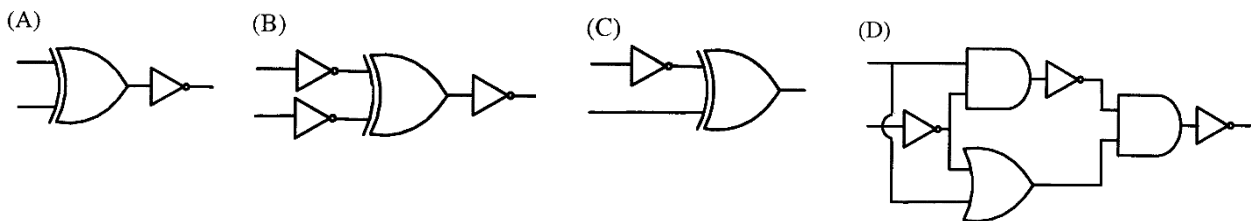

- A _____ is a table which consists of every possible combination of inputs and its corresponding outputs.

- A. Complete table B. K-Map C. Input Table D. None of the above

- The minterm expansion of $\mathbf{F(P,Q,R) = PQ + QR' + PR'}$ is
 A. $m_0+m_1+m_3+m_5$ B. $m_0+m_1+m_6+m_7$ C. $m_2+m_3+m_4+m_5$ D. $m_2+m_4+m_6+m_7$

- Simplify the following using K-map: $\mathbf{F(A,B,C,D) = \Sigma (0,1,2,8,9,12,13)}$ with $\mathbf{D = \Sigma (10,11,14,15)}$
 A. $A+B'D'+B'C'$ B. $A+B'D'+BC$ C. $A+B'C'+B'D'$ D. $A+B'C'$

- Let $\mathbf{f(w,x,y,z) = \sum m (0, 4, 5, 7, 8, 9, 13, 15)}$. Which of the following expressions are NOT equivalent to f?
 A. $w'y'z' + wx'y' + xz$ B. $w'y'z' + wx'y' + xyz + xy'z$ C. $x'y'z' + wx'y' + w'y$ D. $x'y'z' + w'xy' + wy'z + xz$

10. How many two-input OR and AND gates are required to realize $F = AB+CD+E$ respectively?

- A. 2,2 B. 3,2 C. 2,3 D. 3,3

11. Which logic gates are needed to construct an Exclusive-OR (XOR) gate?

- A. OR gates only B. AND gates and NOT gates
 C. AND gates, OR gates and NOT gates D. OR Gates and NOT gates

12. In the given 4-to-1 multiplexer to the right, if $c_1 = 1$ and $c_0 = 0$ then the output M is ____.

- A. X_0
 B. X_1
 C. X_2
 D. X_3

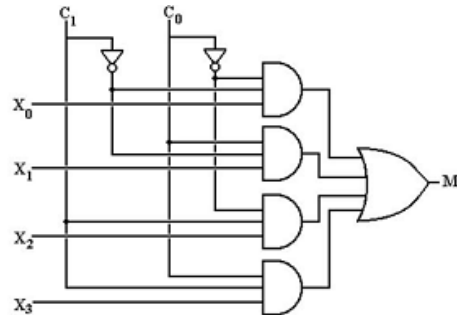

13. Which of the following expressions is in the product-of-sums form?

- A. $(W+X)(Y+Z)$ B. $(WX)(YZ)$ C. $WX(YZ)$ D. $WX + YZ$

14. A cover on a K-map always results in the elimination of _____

- A. Variables within the cover that appear only in their complemented form
 B. Variables that remain unchanged within the cover
 C. Variables within the cover that appear in both complemented and uncomplemented form
 D. Variables within the loop that appear only in their uncomplemented form

15. What is the advantage of CMOS over TTL?

- A. It is larger B. It is cheaper C. It switches faster D. It uses less power

Section B (55 marks)

16. Draw the logical circuits for the two expressions below using only 2 or 3 input NAND gates:

- (i) $xy + xy'z + xyz$ (ii) $ABC + AB'C' + ABC$ (2 x 5 marks)

17. Draw the logical circuits for the two expressions below using 2 or 3 input NOR gates only:

- (i) $(X + Y) . (X' + Y) . (X' + Y')$ (ii) $(X + Y + Z) . (X + Y' + Z')$ (2 x 5 marks)

18. Implement the function $f(A,B,C,D) = \sum m(0,1,3,6,7,10,11,13,14)$ using only one 8-to-1 multiplexer while using D as data input. (12 marks)

19. Given the following circuit below:

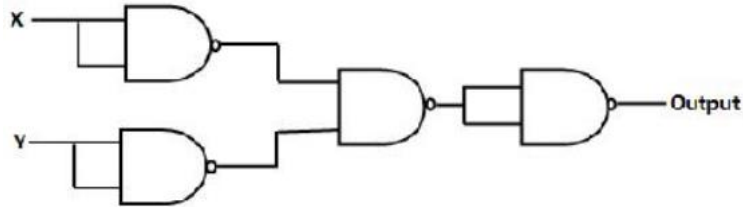

(i) Deduce the equivalent single logic gate it reduces to. (4 marks)

(ii) Redraw the equivalent circuit above using only NOR gates. (3 marks)

20. Given the circuit below:

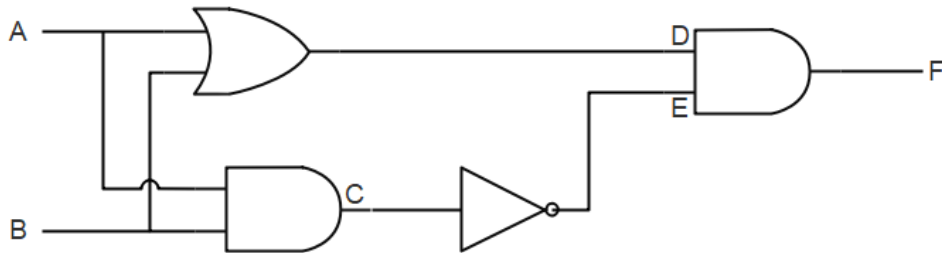

a) Draw a truth table for inputs A and B and output F. (4 marks)

b) Assuming that OR & AND gates each have a propagation delay of 10ns and the NOT gate has a delay of 5 ns, complete the signal diagram given below for the output F and draw the signal levels at the intermediate nodes C, D and E as well. (Assume that both A and B were initially LOW and they both switch to HIGH simultaneously at time t.)

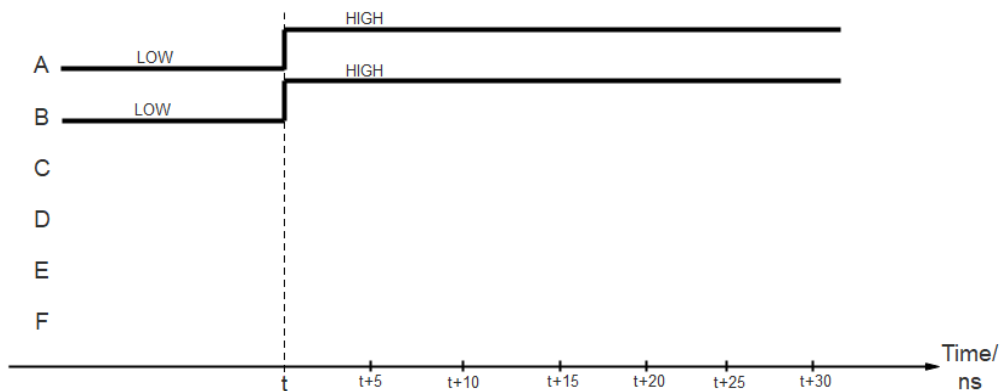

(4x3 marks)

Total Marks: 100

***** END OF CONTROLLED ASSIGNMENT *****